

# The CAHS Journal



published by the  
**CANADIAN  
AVIATION  
HISTORICAL  
SOCIETY**

**VOL. 15 NO. 2 SUMMER 77**

painting by Will Davies



# The CAHS Journal



Published quarterly by the  
Canadian Aviation Historical Society

National Headquarters  
P.O. Box 224, Willowdale, Ontario M2N 5S8

Copyright 1977 CAHS Inc.  
Library code ISSN 007-7771

#### CAHS OFFICERS

	PRESIDENT	F. W. Hotson
	VICE-PRESIDENT	H. R. Johns
	SECRETARY	R. Johnson
	TREASURER	J. H. Ham
MEMBERSHIP	SECRETARY	S. D. Benner
	DIRECTORS	D. E. Anderson
		R. H. Baglow
		R. G. Batch
		C. Catalano
		P. D. Jerden
		G. Stewart
		K. Reed
		W. J. Wheeler
		L. Wilkinson
		R. W. Wylie

#### CAHS JOURNAL STAFF

	EDITOR:	W. J. Wheeler
		4 Rougecrest Dr., Markham, Ont. L3P 3B6
	JOURNAL PRODUCTION	F. W. Hotson
		D. G. MacRitchie
	ASSOCIATE EDITORS	J. R. Ellis
		G. A. Fuller
		H. A. Halliday
		F. W. Hotson
		D. M. Swift
GRAPHICS COMMITTEE		T. Bjarnason
		J. C. Bruce
		J. W. Phipps

**CHAPTER** OTTAWA: R. H. Baglow, P. O. Box 6, R. R. 3, Carp, Ont., K0A 1L0. Tel. 839-5309  
**ADDRESSES:** TORONTO: C. Catalano, 93 Newlands Avenue, Scarborough, Ont., M1L 1S1. Tel. 691-4947  
 VANCOUVER: K. Reed, P. O. Box 48702, Vancouver, B. C., V7X 1A6

The CAHS is incorporated as a non-profit organization under a federal charter.

## contents, summer 77

VOL. 15 NO. 2

Leavens Brothers Montage . . . . .	Will Davies	Cover
President's Message . . . . .	F. W. Hotson	35
Cover Story - Will Davies Montage . .	W. J. Wheeler	35
The Leavens Story . . . . .	Clare Leavens	36
Leavens Fleet Listing . . . . .	M. L. McIntyre	44
The 'Tommy' as I Knew It . . . . .	Mike Sinclair	46
Waco 10 G/A Drawing . . . . .	D. E. Anderson	48
Tempest Tiger S/L D. C. Fairbanks	H. A. Halliday	50
Barnstorming Recollections . . . . .	Mike Sinclair	56
Book Reviews . . . . .		59
Seal Spotting off Newfoundland in 1924 - a report . . . .		60
In Memoriam - John S. Beilby . . . . .	Sam Schlifer	61
The Canadian Search for Nungesser and Coli	K. M. Molson	62
Pitcairn PAA-1 Autogyro G/A Drawing	J. D. Anderson	Rear Cover

#### PHOTO PAGES

The Leavens Story - Plate I . . . . .	37
The Leavens Story - Plate II . . . . .	39
The Leavens Story - Plate III . . . . .	41
The Leavens Story - Plate IV . . . . .	43
The 'Tommy' As I Knew It . . . . .	47
Tempest Tiger - Plate I . . . . .	51
Tempest Tiger - Plate II . . . . .	53
Tempest Tiger - Plate III . . . . .	55
Barnstorming Photos . . . . .	57

This JOURNAL is the official publication of the Canadian Aviation Historical Society. All articles published with authors' names are the opinions of the authors and do not necessarily reflect the policy of the CAHS. All work on this publication is voluntary and no payment can be made for published material.

Members wishing to submit or undertake articles are requested to contact the Editor at his address, given left. All manuscripts for JOURNAL publication should be typed originals (not carbon copies or photocopies), double spaced, using one side only of paper. All material will be returned to owners following its appearance in the JOURNAL.

Membership in the CAHS is for one full calendar year commencing 1st January. A member joining at any time in the year up to 31st December will receive all quarterly JOURNALS for the calendar year of enrolment. Annual membership fees of \$11.00 will be due for renewal on 1st January of each year.

All material published in this JOURNAL is copyright CAHS 1977 and may not be reproduced without written permission.

PITCAIRN PAA-1  
 ATC 433  
 GROSS WEIGHT 1760 LBS  
 EMPTY 1210 LBS  
 FUEL CAP. 27 US GAL

REF U.S. CIVIL AIRCRAFT, JUPTNER  
 VOL 5 P 98 ATC 433  
 VOL 6 P 29 ATC 507

WING  
 AIRFOIL GÖTTINGEN 429  
 COORDS. NOT AVAILABLE

ROTOR SECTION  
 FLAT BOTTOM AIRFOIL

**COLOR SCHEME**

INFORMATION IS SKETCHY HOWEVER A LETTER TO ROSS RICHARDSON FROM FRANK TAYLOR DESCRIBES COLORS AS FOLLOWS:  
 ORIGINAL PAA-1 (KINNER B-5)  
 ALL BLACK WITH WHITE REG. LETTERS ON FUSELAGE. LETTERS MAY NOT HAVE BEEN CARRIED ON WINGS AS NONE SHOW IN PHOTOS.  
 WHEN CONVERSION TO PAA 24 WAS CARRIED OUT THE AIRCRAFT APPEARED WITH THE FEATHERED PATTERN BELOW. BLACK OVER-ALL WITH WHITE LETTERS & RED LOWER FUSELAGE, NOW WITH UNDER-WING LETTERS IN WHITE. ROTORS PROB. ALUM.

1940S NEW FEATHERED SCHEME SEE US CIVIL AIRCRAFT VOL 6 P 31  
 POSTWAR PERIOD, ALL RED WITH YELLOW UPPER FUSE.

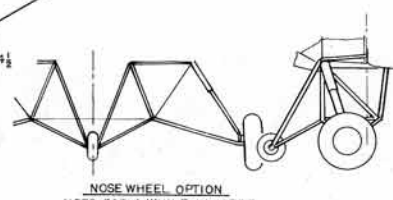
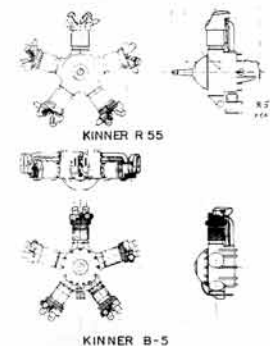
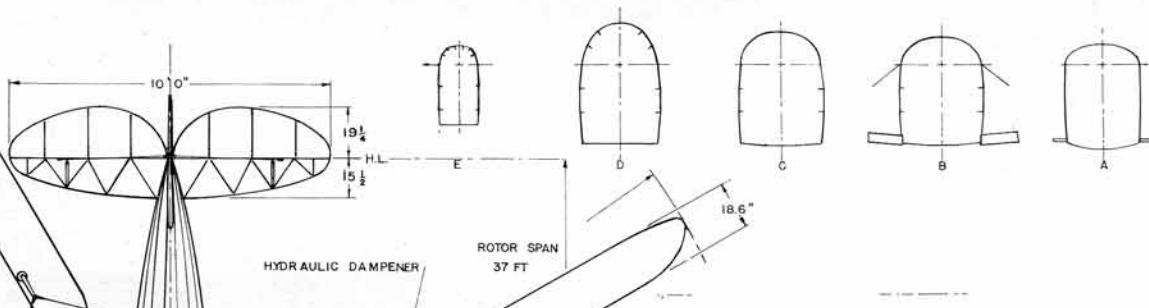

ROTOR BLADES WERE MOUNTED ON UNIVERSAL JOINTS TO HUB. RADIALLY THEY WERE KEPT APART BY CABLES ATTACHED TO HYDRAULIC DAMPENERS. CHECK CABLES ARRESTED DROOP WHILE STATIC BUT BLADES WERE FREE TO SWING UPWARD, DEPENDING ON AERODYNAMIC FORCES TO MAINTAIN EXTENSION  
 OFFSET 1" TO RIGHT AT BASE WITH 1° CANT TO LEFT

ROTOR DRIVE SHAFT CONNECTED ROTOR TO ENGINE FOR STARTING BUT WAS DEGLUTCHED PRIOR TO TAKE-OFF. BLADES FREE WHEELED IN FLIGHT.

CF-ASQ C/N F-72 PREV. NC1648  
 OPERATED BY LEAVENS BROS. AIR SERVICE & FLOWN MOSTLY BY WALT LEAVENS FOR BARN-STORMING, BANNER TOWING & AGRICULTURE & FOREST SPRAYING. IT WAS FLOWN ON SKIS (NO DETAILS AVAILABLE)

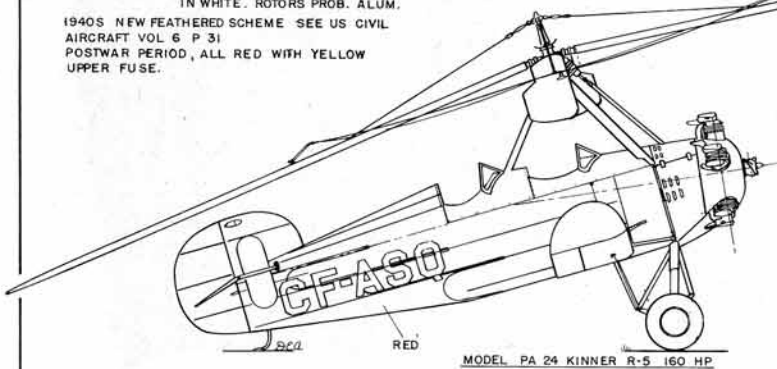
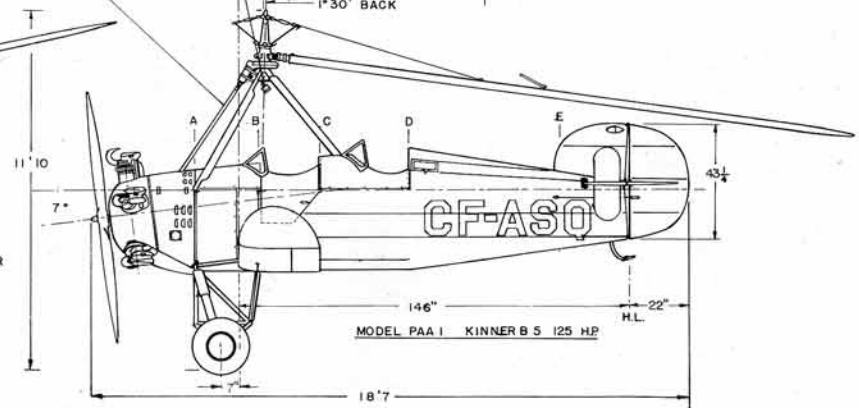
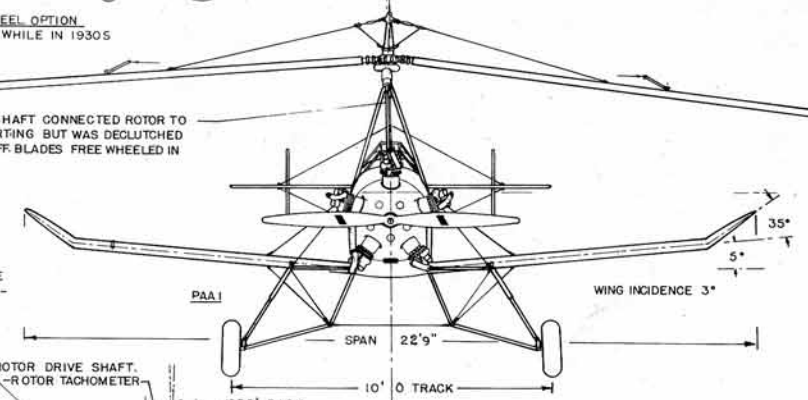

CURTISS REED PROPELLER  
 8' DIA.

MODEL PAA 1 KINNER B 5 125 HP

MODEL PA 24 KINNER R-5 160 HP

THANKS TO  
 BOB LEAVENS, W. ROSS RICHARDSON  
 CHARLIE CATALANO, FRANK TAYLOR  
 PUBLIC ARCHIVES OF CANADA

**PITCAIRN PAA 1 & PA 24**

THE CANADIAN AVIATION HISTORICAL SOCIETY  
 D. E. ANDERSON  
 NOVEMBER 28, 1977

