

The *CAHS* Journal

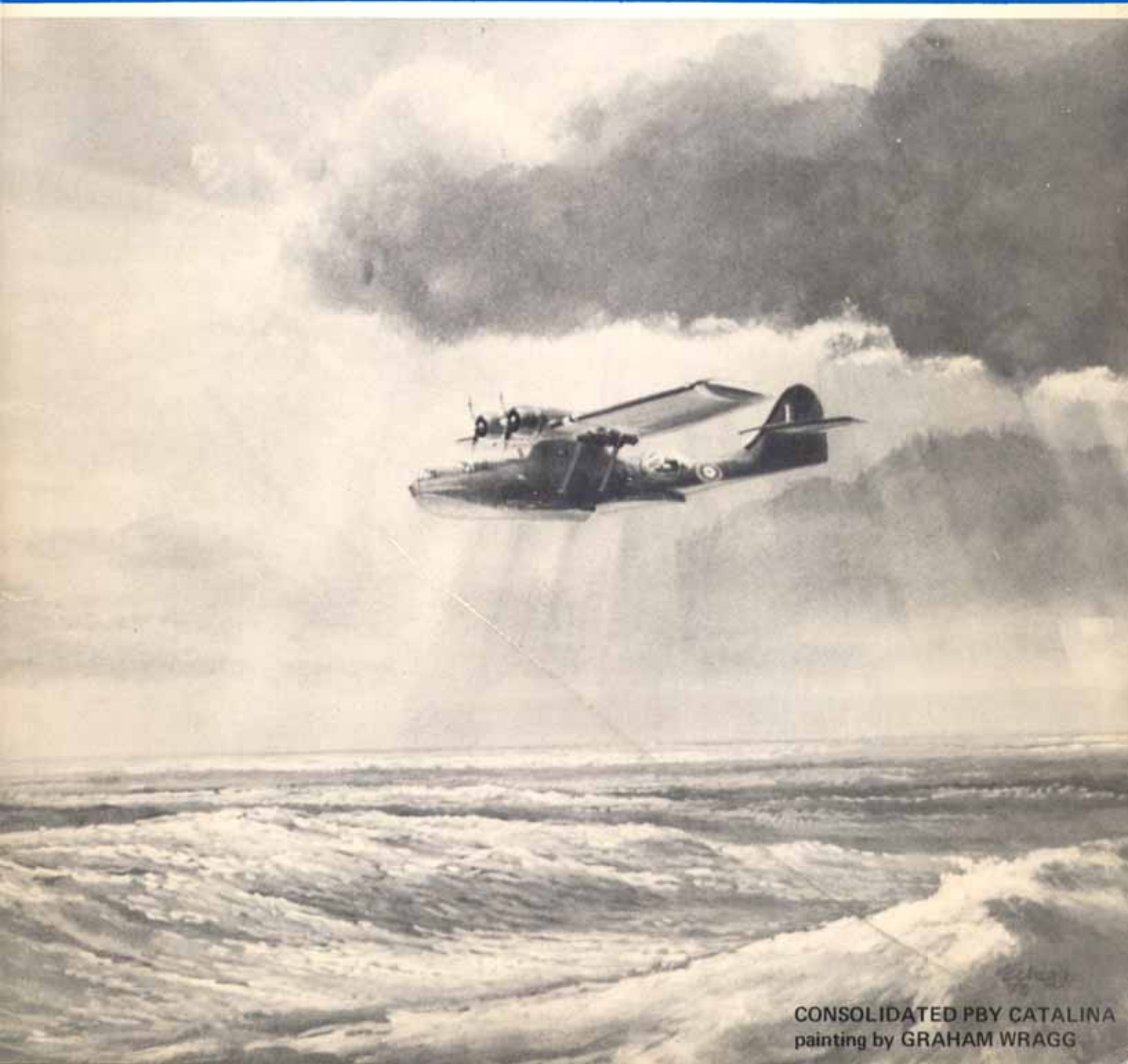

published by the
CANADIAN
AVIATION
HISTORICAL
SOCIETY

VOL 14 NO. 3 FALL 76



CONSOLIDATED PBY CATALINA
painting by GRAHAM WRAGG

The CAHS Journal



Published quarterly by the
Canadian Aviation Historical Society

National Headquarters
P.O. Box 224, Willowdale, Ontario M2N 5S8

Copyright 1976 CAHS Inc.
Library code ISSN 007-7771

CAHS OFFICERS

	PRESIDENT	F. W. Hotson
	VICE-PRESIDENT	H. R. Johns
	SECRETARY	R. Johnson
	TREASURER	J. H. Ham
MEMBERSHIP	SECRETARY	S. D. Benner
	DIRECTORS	D. E. Anderson
		R. H. Baglow
		R. G. Batch
		C. Catalano
		P. D. Jerden
		J. Soulsby
		G. Stewart
		K. Reed
	W. J. Wheeler	
	L. Wilkinson	
	R. W. Wylie	

CAHS JOURNAL STAFF

	EDITOR:	W. J. Wheeler
		4 Rougecrest Dr., Markham, Ont. L3P 3B6
	JOURNAL PRODUCTION	F. W. Hotson
		D. G. MacRitchie
	ASSOCIATE EDITORS	J. R. Ellis
		G. A. Fuller
		H. A. Halliday
		F. W. Hotson
		D. M. Swift
	GRAPHICS COMMITTEE	T. Bjarnason
		J. C. Bruce
		P. M. Mossman
		J. W. Phipps

<u>CHAPTER</u>	MONTREAL:	J. Soulsby, 252 Milton Road, Beaconsfield, P. Q., H9W 1K3. Tel. 697-2246
<u>ADDRESSES:</u>	OTTAWA:	R. H. Baglow, P. O. Box 6, R. R. 3, Carp, Ont., K0A 1L0. Tel. 839-5309
	TORONTO:	C. Catalano, 93 Newlands Avenue, Scarborough, Ont., M1L 1S1. Tel. 691-4947
	VANCOUVER:	K. Reed, P. O. Box 48702, Vancouver, B. C., V7X 1A6

The CAHS is incorporated as a non-profit organization under a federal charter.

contents, fall 76

VOL.14 NO.3 FALL 76

Consolidated PBY Catalina	G. Wragg	Cover
President's Message	F.W. Hotson	67
Great Bear Lake Rescue	H. Hayter & J. Moar	68
In Memoriam : Stuart Graham	J. Beilby	72
Eastern Air Command Recalled	A/M C.L. Annis	73
Consolidated PBY GA Drawing	A. Botting	80
Harold D. West DH-9 Pilot 1918	J.L. Smith	82
McKee Trans-Canada Seaplane Flight	A/V/M A.E. Godfrey	90
CAHS Awards	F.W. Hotson	95
Curtiss Robin	D.E. & J. Anderson	Back Cover

PHOTO PAGES

Great Bear Lake Rescue Photos		70
Eastern Air Command	Plate I	75
	Plate II	79
H.D. West Photos	Plate I	85
	Plate II	87
Recent Reliants	Plate I	88
	Plate II	89
McKee Trans-Canada Photos		93

The Consolidated PBY on the cover of this issue was painted by Graham Wragg of Ottawa.

This JOURNAL is the official publication of the Canadian Aviation Historical Society. All articles published with authors' names are the opinions of the authors and do not necessarily reflect the policy of the CAHS. All work on this publication is voluntary and no payment can be made for published material.

Members wishing to submit or undertake articles are requested to contact the Editor at his address given left. All manuscripts for JOURNAL publication should be typed (if possible), double-spaced, using one side of each sheet only. All material will be returned to owners immediately upon its appearance in the JOURNAL.

Membership in the CAHS is for one full calendar year commencing 1st January. A member joining at any time in the year up to 31st December will receive all quarterly JOURNALS for the calendar year in which he joins. Annual membership fees of \$9.00 will be due for renewal on 1st January of each year.

All material published in this JOURNAL is copyright CAHS 1976 and may not be reproduced without written permission.

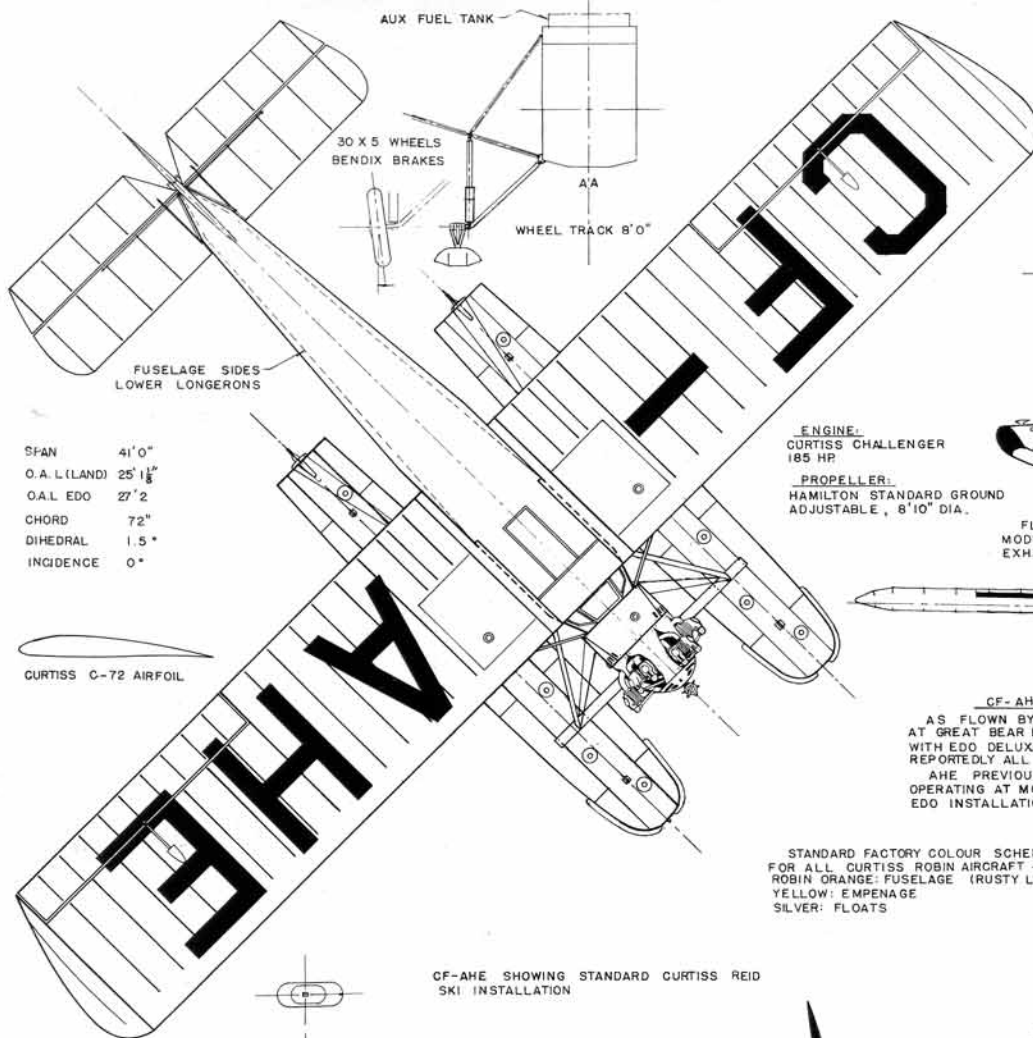

SFAN 41'0"
 O.A.L. (LAND) 25' 1 1/2"
 O.A.L. EDO 27' 2"
 CHORD 72"
 DIHEDRAL 1.5°
 INCIDENCE 0°

CURTISS C-72 AIRFOIL

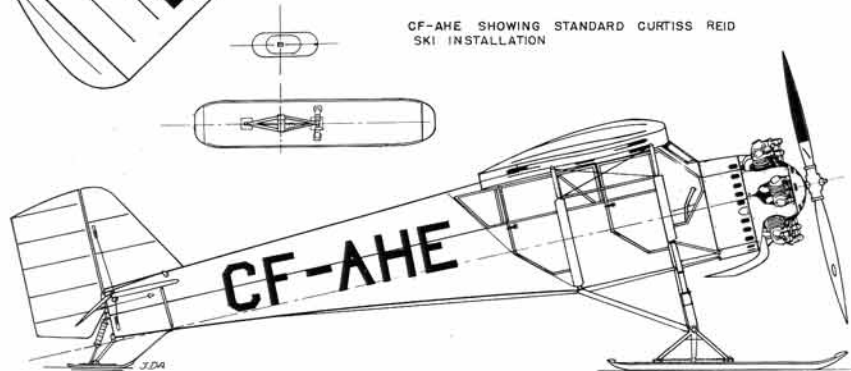

SCALE 1/24 FOR REPRODUCTION 1/72

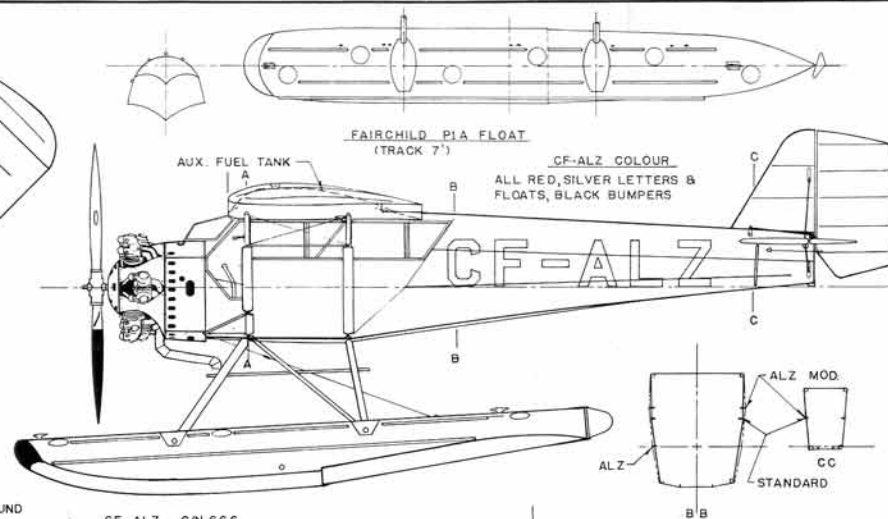

ENGINE:
 CURTISS CHALLENGER
 185 HP

PROPELLER:
 HAMILTON STANDARD GROUND
 ADJUSTABLE, 8'10" DIA.

CF-ALZ C/N 666
 FLOWN BY GEORGE DALZIEL 1935-1939, FT. SIMPSON N.W.T.
 MODIFICATIONS INCLUDE: FUSELAGE STRINGERS, AUX. FUEL TANK,
 EXHAUST PIPE & VEE WINDSHIELD.

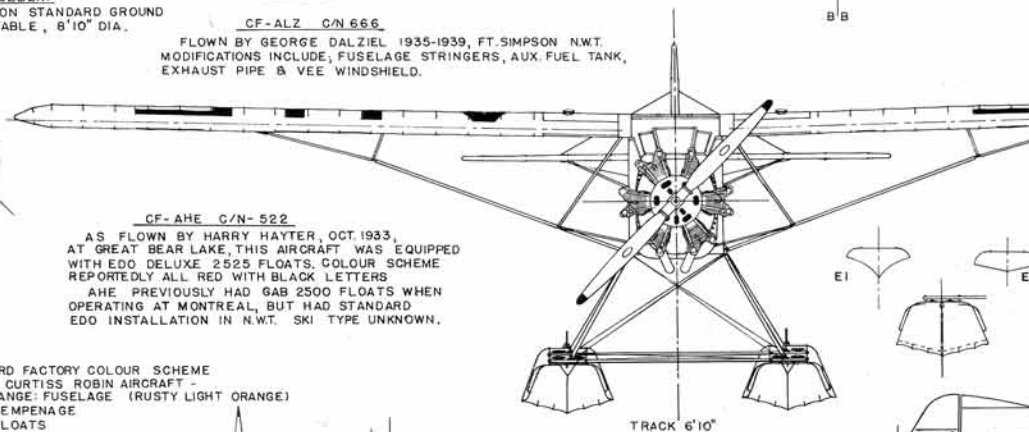

STANDARD FACTORY COLOUR SCHEME
 FOR ALL CURTISS ROBIN AIRCRAFT -
 ROBIN ORANGE: FUSELAGE (RUSTY LIGHT ORANGE);
 YELLOW: EMPENAGE
 SILVER: FLOATS

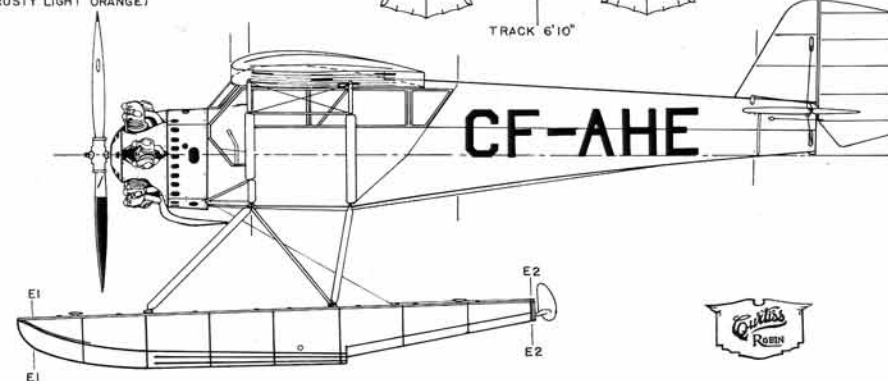

CURTISS ROBIN C-1
 THE CANADIAN AVIATION HISTORICAL SOCIETY

DRAWN BY JAMES D. ANDERSON JAN. 1977

DRAWN FROM TECHNICAL MATERIAL IN COLLECTION OF D. E. ANDERSON